

# MOD:XEBC-10EU-EPR



## ENGLISH

## TECHNICAL DATA

- 01 POWER
- 03 FREQUENCY
- 04 POWER SUPPLY CABLE TYPE
- 05 EXTERNAL Ø OF POWER SUPPLY CABLE
- 06 VOLTAGE / POWER CABLE SECTION / CURRENT

21 kW  
50 / 60 Hz  
H07RN-F  
16 mm

380-415 V~3PH+N+PE  
5G x 4 mm<sup>2</sup>  
I1=29 A - I2=29 A - I3=32.6 A - In=3.6 A

x  
I1= - I2= - I3= - In=

x  
I1= - I2= - I3= - In=

- 10 WATER PRESSURE
- 11 MAX FOOD LOAD
- 13 WATER MAX CONSUMPTION
- 02 NOMINAL HEAT INPUT
- 18 CAVITY DIMENSIONS ( W - D - H )
- 20 DEGREE OF PROTECTION IP

150-600 kPa / 21-87 psi kPa  
50 kg  
14.7 l/h @ 200 kPa  
20.25 kW  
716x560x880 mm  
IPX4

## ITALIANO

- 01 POTENZA
- 03 FREQUENZA
- 04 TIPO DI CAVO ALIMENTAZIONE
- 05 Ø ESTERNO CAVO DI ALIMENTAZIONE
- 06 TENSIONE / SEZIONE CAVI ALIMENTAZIONE / CORRENTE
- 10 PRESSIONE ACQUA
- 11 CARICA MAX CIBO
- 13 CONSUMO MAX ACQUA
- 02 POTENZA TERMICA NOMINALE
- 18 DIMENSIONI CAMERA COTTURA ( L - P - H )
- 20 GRADO PROTEZIONE IP

## FRANCAIS

- 01 PUISSANCE ELECTRIQUE
- 03 FREQUENCE
- 04 TYPE DE CABLE D'ALIMENTATION
- 05 Ø EXTERNE DU CABLE D'ALIMENTATION
- 06 TENSION / SECTION CABLE D'ALIM.
- 10 PRESSION DE L'EAU
- 11 CHARGE MAXIMALE D'ALIMENT
- 13 CONSOMMATION MAX DE L'EAU
- 02 DEBIT THERMIQUE NOMINAL
- 18 DIMENSIONS CHAMBRE DE CUISSON ( L - P - A )
- 20 INDICE DE PROTECTION IP

## ESPAÑOL

- 01 POTENCIA
- 03 FRECUENCIA
- 04 TIPO DE CABLE DE ALIMENTACION
- 05 Ø CABLE EXTERNO DE ALIMENTACION
- 06 TENSION / SECCION CABLES DE ALIMENTACION
- 10 PRESION AGUA
- 11 CARGA MAX. DE ALIMENTOS
- 13 CONSUMO MAX DE AGUA
- 02 POTENCIA TERMICA NOMINAL
- 18 DIMENSIONES CÁMARA DE COCCIÓN ( A - A - P )
- 20 GRADO DE PROTECCION IP

## DEUTSCH

- 01 ELEKTRISCHE LEISTUNG
- 03 FREQUENZ
- 04 ZULEITUNGSKABELTYP
- 05 AUSSENDURCHMESSER DES VERSORGUNGSKABELS
- 06 KABELQUERSCHNITT UND VERSORGUNGSSPANNUNG
- 10 WASSERDRUCK
- 11 MAX. SPEISENFASSUNGSVERMOGEN
- 13 MAXIMUM WASSERVERBRAUCH
- 02 NOMINALE WARMELEISTUNG
- 18 GRÖßE DES KOCHKAMMERS ( B - T - H )
- 20 SCHTZART IP



# MOD:XEBC-10EU-EPR



## ENGLISH - DRAWINGS

1	TERMINAL BOARD COVER BOX
2	TERMINAL BOARD POWER SUPPLY
3	UNIPOTENTIAL TERMINAL
6	TECHNICAL DATA PLATE
7	SAFETY THERMOSTAT
8	3/4" THREAD WATER INLET
10	Rotor.KLEAN CONNECTION
11	CAVITY DRAIN PIPE
12	HOT FUMES EXHAUST CHIMNEY
13	ACCESSORIES CONNECTION
27	COOLING AIR OUTLET

## ITALIANO - DISEGNI

1	SCATOLA COPRI MORSETTIERA
2	MORSETTIERA ALIMENTAZIONE
3	MORSETTO EQUIPOTENZIALE
6	TARGHETTA DATI TECNICI
7	TERMOSTATO DI SICUREZZA
8	INGRESSO ACQUA 3/4"
10	INGRESSO Rotor.KLEAN
11	SCARICO CAMERA DI COTTURA
12	USCITA FUMI CALDI
13	COLLEGAMENTO ACCESSORI
27	USCITA ARIA DI RAFFREDDAMENTO

## FRANCAIS - ENCOMBREMEN

1	CHAUMARD
2	BOITE A BORNES D'ALIMENTATION
3	SUPPORT BORNE EQUIPOTENTIELLE
6	PLAQUETTE SEGNALETIQUE
7	THERMOSTAT DE SECURITE
8	ARRIVE' D'EAU FIELT 3/4"
10	ENTREE Rotor.KLEAN
11	SORTIE DE L'EAU RACCORD
12	SORTIE DES FUMEEES CHAUDES
13	JONCTION DES ACCESSOIRES
27	SORTIE D'EAU DE REFROIDISSEMENT

## ESPAÑOL - DISEÑOS

1	PASA CABLE
2	CAJA DE CONEXION
3	SEDE BORNE EQUIPOTENCIAL
6	TARJETA DE CARACTERISTICAS TECNICAS
7	TERMOSTATO DE SEGURIDAD
8	ENTRADA DE AGUA 3/4"
10	INGRESO Rotor.KLEAN
11	DESCARGA CAMARA DE COCCION
12	SALIDA HUMOS CALIENTES
13	CONEXION ACCESORIOS
27	SALIDA DEL AIRE DE ENFRIAMIENTO

## DEUTSCH - ZEICHNUNGEN

1	KLEMMLEISTENANSCHLUSS
2	ZULEITUNGSKLEMMLEISTE
3	GLEICHPOTENTIELLE KLAMMER
6	TYPENSCHILD
7	SICHERHEITSTHERMOSTAT
8	WASSEREINZUG 3/4" GEWINDE
10	Rotor.KLEAN EINGANG
11	WASSERAUSLASS GEWINDE
12	ABZUGSHAUBE
13	ZUBEHÖRTEILENVERBINDUNG
27	KÜHLLUFTAUSTRITT

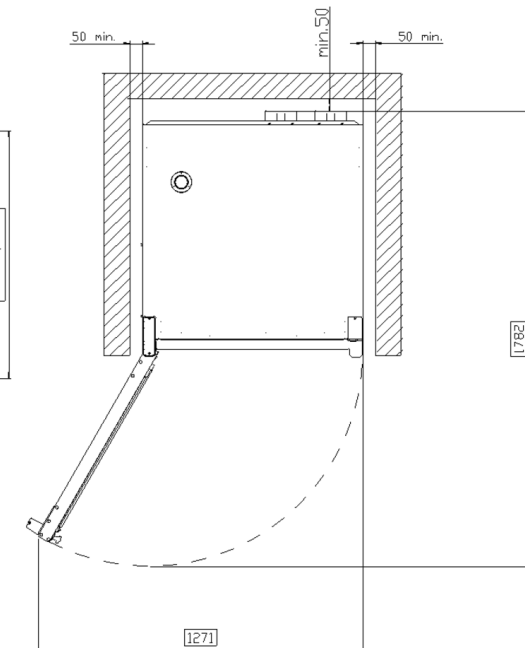
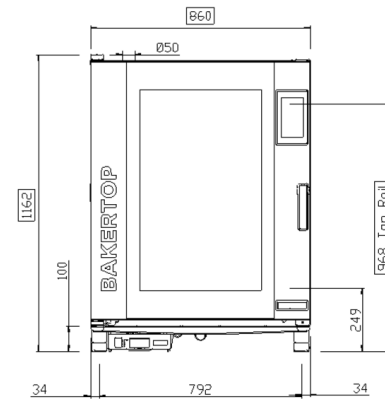
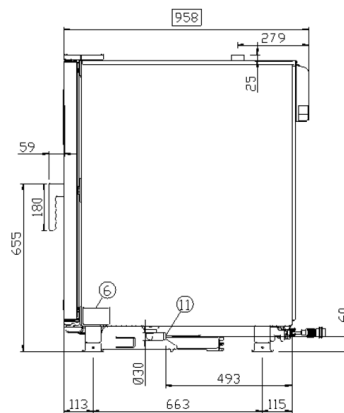
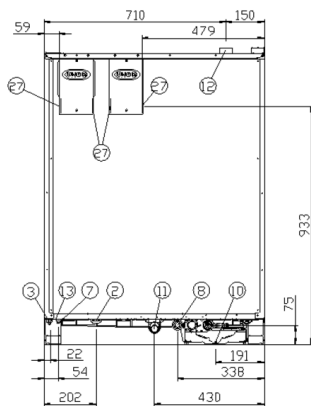

# MOD:XEBC-10EU-EPR

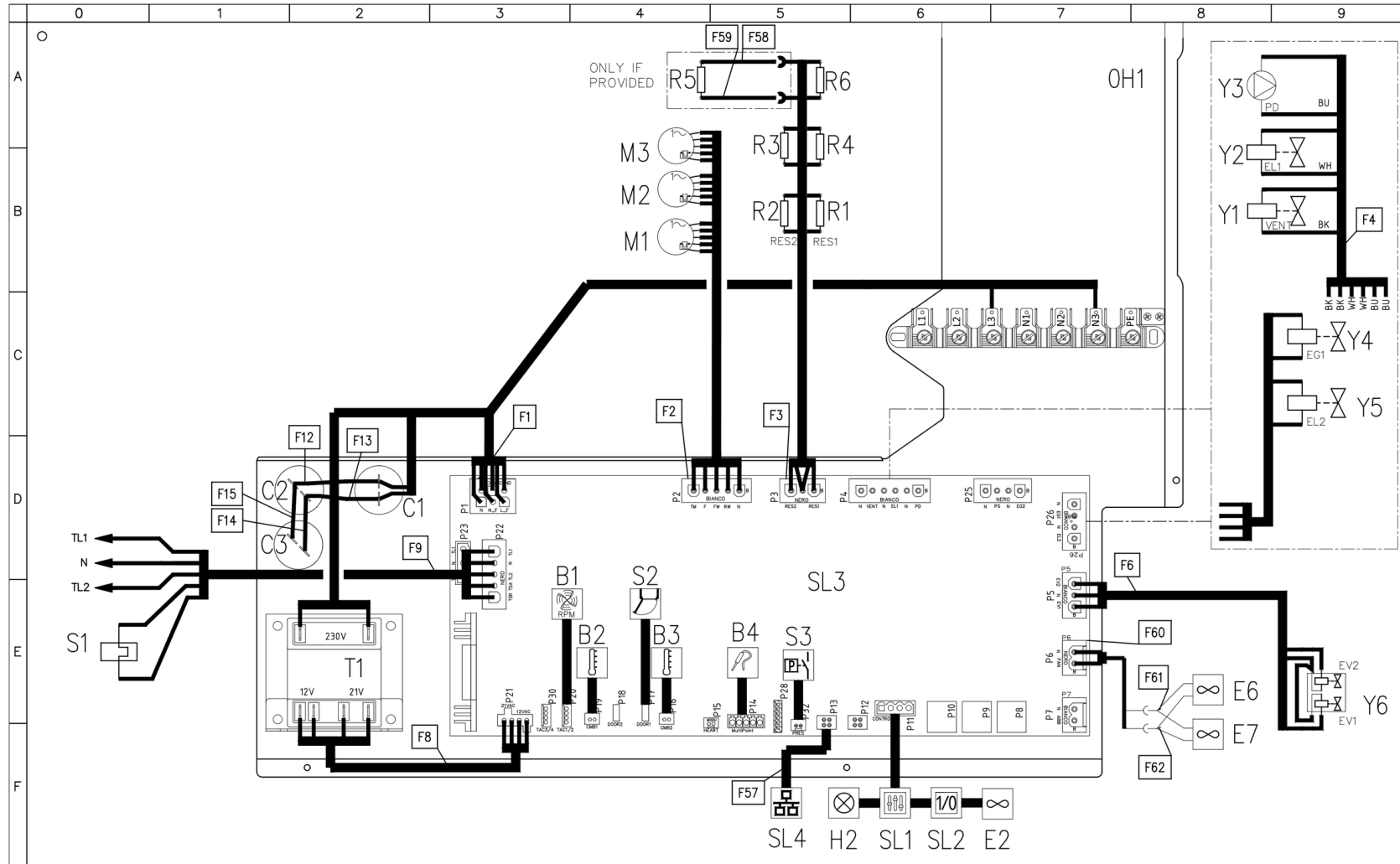

# MOD:XEBC-10EU-EPR

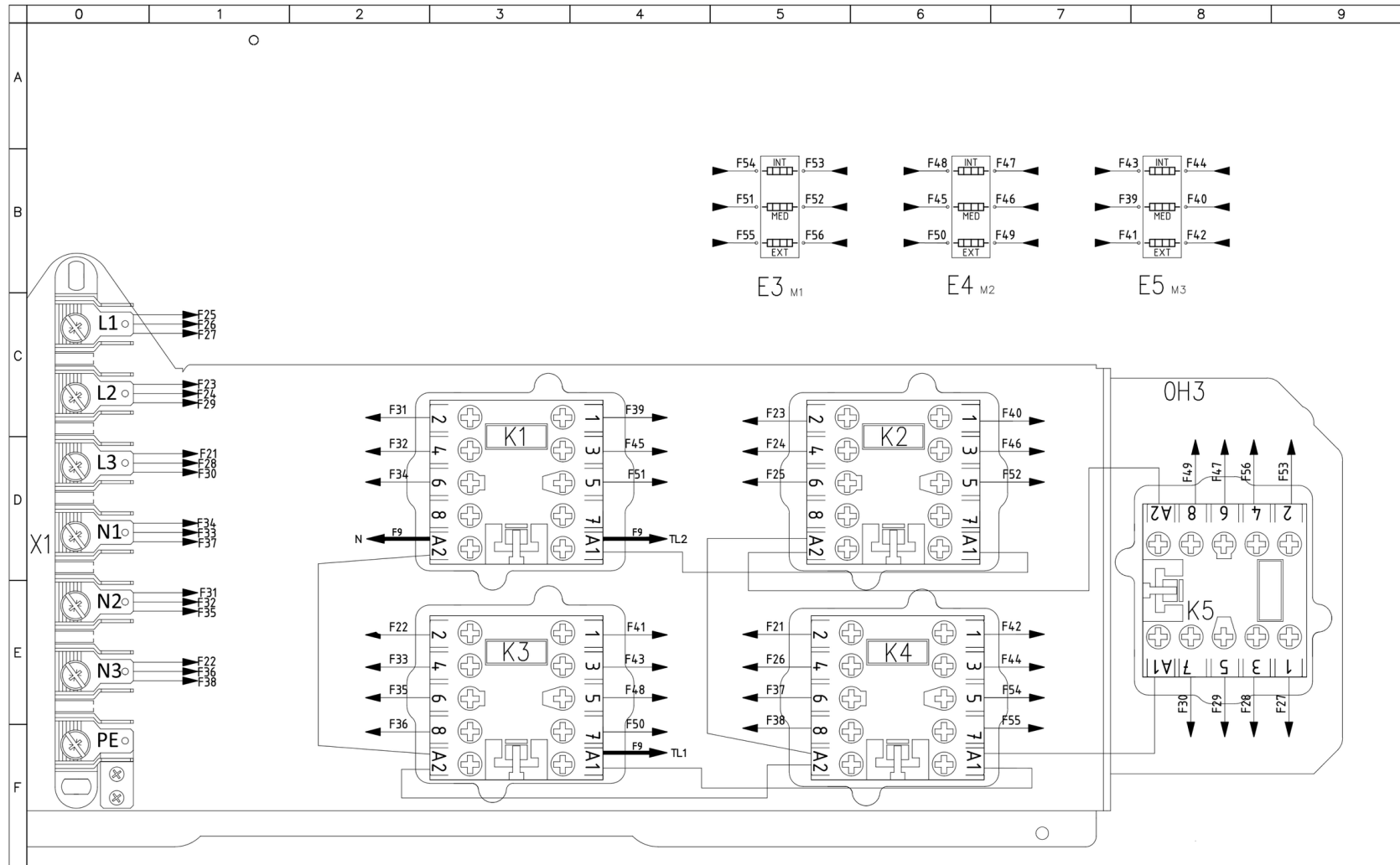

# MOD:XEBC-10EU-EPR



	0	1	2	3	4	5	6	7	8	9																																																																																																																																																
A																																																																																																																																																										
B																																																																																																																																																										
C	Q	<table border="1"> <thead> <tr> <th>Q</th> <th>ITALIANO</th> <th>ENGLISH</th> <th>FRANCAIS</th> <th>ESPAÑOL</th> <th>DEUTSCH</th> </tr> </thead> <tbody> <tr> <td>B1</td> <td>SENSORE VELOCITA MOTORE</td> <td>MOTOR SPEED SENSOR</td> <td>CAPTEUR DE VITESSE MOTEUR</td> <td>SENSOR DE VELOCIDAD MOTOR</td> <td>GESCHWINDIGKEITSSENSOR</td> </tr> <tr> <td>B2,B3</td> <td>SONDA CAMERA</td> <td>TEMPERATURE PROBE</td> <td>SONDE DE CHAMBRE</td> <td>SONDA CAMARA</td> <td>GARRAUMTEMPERATURFUHLER</td> </tr> <tr> <td>B4</td> <td>SONDA AL CUORE</td> <td>CORE PROBE</td> <td>SONDE A COEUR</td> <td>SONDA CORAZON</td> <td>KERNTEMPERATURFUHLER</td> </tr> <tr> <td>C1,C2,C3</td> <td>CONDENSATORE</td> <td>MOTOR CAPACITOR</td> <td>CONDENSATEUR</td> <td>CONDENSADOR</td> <td>KONDENSATOR</td> </tr> <tr> <td>E1,E6,E7</td> <td>VENTOLA RAFFREDDAMENTO</td> <td>COOLING FAN</td> <td>TURBINE DE REFRROIDISSEMENT</td> <td>TURBINA DE REFRIGERACION</td> <td>LÜFTER</td> </tr> <tr> <td>E3,E4,E5</td> <td>ELEMENTO RISCALDANTE</td> <td>HEATING ELEMENT</td> <td>ELEMENT DE CHAUFFAGE</td> <td>RESISTENCIA DE CALEFACCIÓN</td> <td>HEIZUNG</td> </tr> <tr> <td>H2</td> <td>LUCE CAMERA</td> <td>OVEN LIGHT</td> <td>ECLAIRAGE DE CHAMBRE</td> <td>LUZ CAMARA</td> <td>BELEUCHTUNG</td> </tr> <tr> <td>K1,K2,K3,K4,K5</td> <td>TELERUTTORE</td> <td>CONTACTOR</td> <td>TELERUPTEUR</td> <td>TELERRUPTOR</td> <td>RELAIS</td> </tr> <tr> <td>M1,M2,M3</td> <td>MOTORE</td> <td>MOTOR</td> <td>MOTEUR</td> <td>MOTOR</td> <td>MOTOR</td> </tr> <tr> <td>R1,R2,R3,R4,R5,R6</td> <td>RESISTENZA DI MODULAZIONE VENTILATORE</td> <td>MOTOR MODULATION RESISTANCE</td> <td>RESISTANCE DE MODULATION VENTILATEUR</td> <td>RESISTENCIA MODULACION VELOCIDAD</td> <td>WIDERSTAND LOW FAN</td> </tr> <tr> <td>S1</td> <td>TERMOSTATO SICUREZZA</td> <td>SAFETY THERMOSTAT</td> <td>THERMOSTAT DE SECURITE</td> <td>TERMOSTATO DE SEGURIDAD</td> <td>SICHERHEITS THERMOSTAT</td> </tr> <tr> <td>S2</td> <td>MICRO INTERRUTTORE PORTA</td> <td>DOOR MICROSWITCH</td> <td>MICROINTERRUPTEUR DE PORTE</td> <td>MICROINTERRUPTOR PUERTA</td> <td>TURKONTAKTSCHALTER</td> </tr> <tr> <td>S3</td> <td>PRESSOSTATO</td> <td>PRESSURE SWITCH</td> <td>PRESSOSTAT</td> <td>PRESÓSTATO</td> <td>DRUCKSCHALTER</td> </tr> <tr> <td>SL1</td> <td>SCHEDA CONTROLLO</td> <td>CONTROL BOARD</td> <td>CARTE DE CONTROLE</td> <td>TARJETA DE CONTROL</td> <td>KONTROLL PLATINE</td> </tr> <tr> <td>SL2</td> <td>SCHEDA 1/0 – USB</td> <td>1/0 BOARD – USB</td> <td>CARTE 1/0 – USB</td> <td>TARJETA 1/0 – USB</td> <td>1/0 PLATINE – USB</td> </tr> <tr> <td>SL3</td> <td>SCHEDA POTENZA</td> <td>POWER CARD</td> <td>CARTE DE PUISSANCE</td> <td>POWERPLATINE</td> <td>TARJETA POTENCIA</td> </tr> <tr> <td>SL4</td> <td>BRIDGE ETHERNET</td> <td>BRIDGE ETHERNET</td> <td>BRIDGE ETHERNET</td> <td>BRIDGE ETHERNET</td> <td>BRIDGE ETHERNET</td> </tr> <tr> <td>T1</td> <td>TRASFORMATORE</td> <td>TRANSFORMER</td> <td>TRASFORMATEUR</td> <td>TRANSFORMADOR</td> <td>TRASFORMATORE</td> </tr> <tr> <td>X1</td> <td>MORSETTIERA</td> <td>CONTACTOR</td> <td>BORNIER</td> <td>CONECTOR</td> <td>KLEMMLEISTE</td> </tr> <tr> <td>Y1</td> <td>DRY MAXY</td> <td>DRY MAXY</td> <td>DRY MAXY</td> <td>DRY MAXY</td> <td>DRY MAXY</td> </tr> <tr> <td>Y2,Y4,Y5</td> <td>ELETTROVALVOLA ACQUA</td> <td>WATER SOLENOID VALVE</td> <td>ELECTROVANNE EAU</td> <td>ELECTROVALVULA</td> <td>ELEKTROVENTIL</td> </tr> <tr> <td>Y3</td> <td>POMPA</td> <td>PUMP</td> <td>POMPE</td> <td>BOMBA</td> <td>PUMPE</td> </tr> <tr> <td>Y6</td> <td>ELETTROVALVOLA ACQUA</td> <td>WATER SOLENOID VALVE</td> <td>ELECTROVANNE EAU</td> <td>ELECTROVALVULA</td> <td>ELEKTROVENTIL</td> </tr> </tbody> </table>									Q	ITALIANO	ENGLISH	FRANCAIS	ESPAÑOL	DEUTSCH	B1	SENSORE VELOCITA MOTORE	MOTOR SPEED SENSOR	CAPTEUR DE VITESSE MOTEUR	SENSOR DE VELOCIDAD MOTOR	GESCHWINDIGKEITSSENSOR	B2,B3	SONDA CAMERA	TEMPERATURE PROBE	SONDE DE CHAMBRE	SONDA CAMARA	GARRAUMTEMPERATURFUHLER	B4	SONDA AL CUORE	CORE PROBE	SONDE A COEUR	SONDA CORAZON	KERNTEMPERATURFUHLER	C1,C2,C3	CONDENSATORE	MOTOR CAPACITOR	CONDENSATEUR	CONDENSADOR	KONDENSATOR	E1,E6,E7	VENTOLA RAFFREDDAMENTO	COOLING FAN	TURBINE DE REFRROIDISSEMENT	TURBINA DE REFRIGERACION	LÜFTER	E3,E4,E5	ELEMENTO RISCALDANTE	HEATING ELEMENT	ELEMENT DE CHAUFFAGE	RESISTENCIA DE CALEFACCIÓN	HEIZUNG	H2	LUCE CAMERA	OVEN LIGHT	ECLAIRAGE DE CHAMBRE	LUZ CAMARA	BELEUCHTUNG	K1,K2,K3,K4,K5	TELERUTTORE	CONTACTOR	TELERUPTEUR	TELERRUPTOR	RELAIS	M1,M2,M3	MOTORE	MOTOR	MOTEUR	MOTOR	MOTOR	R1,R2,R3,R4,R5,R6	RESISTENZA DI MODULAZIONE VENTILATORE	MOTOR MODULATION RESISTANCE	RESISTANCE DE MODULATION VENTILATEUR	RESISTENCIA MODULACION VELOCIDAD	WIDERSTAND LOW FAN	S1	TERMOSTATO SICUREZZA	SAFETY THERMOSTAT	THERMOSTAT DE SECURITE	TERMOSTATO DE SEGURIDAD	SICHERHEITS THERMOSTAT	S2	MICRO INTERRUTTORE PORTA	DOOR MICROSWITCH	MICROINTERRUPTEUR DE PORTE	MICROINTERRUPTOR PUERTA	TURKONTAKTSCHALTER	S3	PRESSOSTATO	PRESSURE SWITCH	PRESSOSTAT	PRESÓSTATO	DRUCKSCHALTER	SL1	SCHEDA CONTROLLO	CONTROL BOARD	CARTE DE CONTROLE	TARJETA DE CONTROL	KONTROLL PLATINE	SL2	SCHEDA 1/0 – USB	1/0 BOARD – USB	CARTE 1/0 – USB	TARJETA 1/0 – USB	1/0 PLATINE – USB	SL3	SCHEDA POTENZA	POWER CARD	CARTE DE PUISSANCE	POWERPLATINE	TARJETA POTENCIA	SL4	BRIDGE ETHERNET	BRIDGE ETHERNET	BRIDGE ETHERNET	BRIDGE ETHERNET	BRIDGE ETHERNET	T1	TRASFORMATORE	TRANSFORMER	TRASFORMATEUR	TRANSFORMADOR	TRASFORMATORE	X1	MORSETTIERA	CONTACTOR	BORNIER	CONECTOR	KLEMMLEISTE	Y1	DRY MAXY	DRY MAXY	DRY MAXY	DRY MAXY	DRY MAXY	Y2,Y4,Y5	ELETTROVALVOLA ACQUA	WATER SOLENOID VALVE	ELECTROVANNE EAU	ELECTROVALVULA	ELEKTROVENTIL	Y3	POMPA	PUMP	POMPE	BOMBA	PUMPE	Y6	ELETTROVALVOLA ACQUA	WATER SOLENOID VALVE	ELECTROVANNE EAU	ELECTROVALVULA	ELEKTROVENTIL
Q	ITALIANO	ENGLISH	FRANCAIS	ESPAÑOL	DEUTSCH																																																																																																																																																					
B1	SENSORE VELOCITA MOTORE	MOTOR SPEED SENSOR	CAPTEUR DE VITESSE MOTEUR	SENSOR DE VELOCIDAD MOTOR	GESCHWINDIGKEITSSENSOR																																																																																																																																																					
B2,B3	SONDA CAMERA	TEMPERATURE PROBE	SONDE DE CHAMBRE	SONDA CAMARA	GARRAUMTEMPERATURFUHLER																																																																																																																																																					
B4	SONDA AL CUORE	CORE PROBE	SONDE A COEUR	SONDA CORAZON	KERNTEMPERATURFUHLER																																																																																																																																																					
C1,C2,C3	CONDENSATORE	MOTOR CAPACITOR	CONDENSATEUR	CONDENSADOR	KONDENSATOR																																																																																																																																																					
E1,E6,E7	VENTOLA RAFFREDDAMENTO	COOLING FAN	TURBINE DE REFRROIDISSEMENT	TURBINA DE REFRIGERACION	LÜFTER																																																																																																																																																					
E3,E4,E5	ELEMENTO RISCALDANTE	HEATING ELEMENT	ELEMENT DE CHAUFFAGE	RESISTENCIA DE CALEFACCIÓN	HEIZUNG																																																																																																																																																					
H2	LUCE CAMERA	OVEN LIGHT	ECLAIRAGE DE CHAMBRE	LUZ CAMARA	BELEUCHTUNG																																																																																																																																																					
K1,K2,K3,K4,K5	TELERUTTORE	CONTACTOR	TELERUPTEUR	TELERRUPTOR	RELAIS																																																																																																																																																					
M1,M2,M3	MOTORE	MOTOR	MOTEUR	MOTOR	MOTOR																																																																																																																																																					
R1,R2,R3,R4,R5,R6	RESISTENZA DI MODULAZIONE VENTILATORE	MOTOR MODULATION RESISTANCE	RESISTANCE DE MODULATION VENTILATEUR	RESISTENCIA MODULACION VELOCIDAD	WIDERSTAND LOW FAN																																																																																																																																																					
S1	TERMOSTATO SICUREZZA	SAFETY THERMOSTAT	THERMOSTAT DE SECURITE	TERMOSTATO DE SEGURIDAD	SICHERHEITS THERMOSTAT																																																																																																																																																					
S2	MICRO INTERRUTTORE PORTA	DOOR MICROSWITCH	MICROINTERRUPTEUR DE PORTE	MICROINTERRUPTOR PUERTA	TURKONTAKTSCHALTER																																																																																																																																																					
S3	PRESSOSTATO	PRESSURE SWITCH	PRESSOSTAT	PRESÓSTATO	DRUCKSCHALTER																																																																																																																																																					
SL1	SCHEDA CONTROLLO	CONTROL BOARD	CARTE DE CONTROLE	TARJETA DE CONTROL	KONTROLL PLATINE																																																																																																																																																					
SL2	SCHEDA 1/0 – USB	1/0 BOARD – USB	CARTE 1/0 – USB	TARJETA 1/0 – USB	1/0 PLATINE – USB																																																																																																																																																					
SL3	SCHEDA POTENZA	POWER CARD	CARTE DE PUISSANCE	POWERPLATINE	TARJETA POTENCIA																																																																																																																																																					
SL4	BRIDGE ETHERNET	BRIDGE ETHERNET	BRIDGE ETHERNET	BRIDGE ETHERNET	BRIDGE ETHERNET																																																																																																																																																					
T1	TRASFORMATORE	TRANSFORMER	TRASFORMATEUR	TRANSFORMADOR	TRASFORMATORE																																																																																																																																																					
X1	MORSETTIERA	CONTACTOR	BORNIER	CONECTOR	KLEMMLEISTE																																																																																																																																																					
Y1	DRY MAXY	DRY MAXY	DRY MAXY	DRY MAXY	DRY MAXY																																																																																																																																																					
Y2,Y4,Y5	ELETTROVALVOLA ACQUA	WATER SOLENOID VALVE	ELECTROVANNE EAU	ELECTROVALVULA	ELEKTROVENTIL																																																																																																																																																					
Y3	POMPA	PUMP	POMPE	BOMBA	PUMPE																																																																																																																																																					
Y6	ELETTROVALVOLA ACQUA	WATER SOLENOID VALVE	ELECTROVANNE EAU	ELECTROVALVULA	ELEKTROVENTIL																																																																																																																																																					
D																																																																																																																																																										
E																																																																																																																																																										
F																																																																																																																																																										

# MOD:XEBC-10EU-EPR



## ED1408A POWER SUPPLY - CONNECTION DIAGRAM

380-415V ~ 3PH + N + PE 50/60Hz

