

# MOD:XEVC-0511-EPR



## ENGLISH

## TECHNICAL DATA

- 01 POWER
- 03 FREQUENCY
- 04 POWER SUPPLY CABLE TYPE
- 05 EXTERNAL Ø OF POWER SUPPLY CABLE
- 06 VOLTAGE / POWER CABLE SECTION / CURRENT

9,3 kW  
50 / 60 Hz  
H07RN-F  
16 mm

380-415 V~3PH+N+PE  
5G x 2,5 mm<sup>2</sup>  
I1=13 A - I2=13 A - I3=14 A - In=1 A

220-240 V~3PH+PE  
4G x 4 mm<sup>2</sup>  
I1=23 A - I2=24 A - I3=24 A - In=

x  
I1= - I2= - I3= - In=

- 10 WATER PRESSURE
- 11 MAX FOOD LOAD
- 13 WATER MAX CONSUMPTION
- 02 NOMINAL HEAT INPUT
- 18 CAVITY DIMENSIONS ( W - D - H )
- 20 DEGREE OF PROTECTION IP

150-600 kPa / 21-87 psi kPa  
25 kg  
6.5 l/h @ 200 kPa  
9 kW  
606x385x392 mm  
IPX4

## ITALIANO

- 01 POTENZA
- 03 FREQUENZA
- 04 TIPO DI CAVO ALIMENTAZIONE
- 05 Ø ESTERNO CAVO DI ALIMENTAZIONE
- 06 TENSIONE / SEZIONE CAVI ALIMENTAZIONE / CORRENTE
- 10 PRESSIONE ACQUA
- 11 CARICA MAX CIBO
- 13 CONSUMO MAX ACQUA
- 02 POTENZA TERMICA NOMINALE
- 18 DIMENSIONI CAMERA COTTURA ( L - P - H )
- 20 GRADO PROTEZIONE IP

## FRANCAIS

- 01 PUISSANCE ELECTRIQUE
- 03 FREQUENCE
- 04 TYPE DE CABLE D'ALIMENTATION
- 05 Ø EXTERNE DU CABLE D'ALIMENTATION
- 06 TENSION / SECTION CABLE D'ALIM.
- 10 PRESSION DE L'EAU
- 11 CHARGE MAXIMALE D'ALIMENT
- 13 CONSOMMATION MAX DE L'EAU
- 02 DEBIT THERMIQUE NOMINAL
- 18 DIMENSIONS CHAMBRE DE CUISSON ( L - P - A )
- 20 INDICE DE PROTECTION IP

## ESPAÑOL

- 01 POTENCIA
- 03 FRECUENCIA
- 04 TIPO DE CABLE DE ALIMENTACION
- 05 Ø CABLE EXTERNO DE ALIMENTACION
- 06 TENSION / SECCION CABLES DE ALIMENTACION
- 10 PRESION AGUA
- 11 CARGA MAX. DE ALIMENTOS
- 13 CONSUMO MAX DE AGUA
- 02 POTENCIA TERMICA NOMINAL
- 18 DIMENSIONES CÁMARA DE COCCIÓN ( A - A - P )
- 20 GRADO DE PROTECCION IP

## DEUTSCH

- 01 ELEKTRISCHE LEISTUNG
- 03 FREQUENZ
- 04 ZULEITUNGSKABELTYP
- 05 AUSSENDURCHMESSER DES VERSORGUNGSKABELS
- 06 KABELQUERSCHNITT UND VERSORGUNGSSPANNUNG
- 10 WASSERDRUCK
- 11 MAX. SPEISENFASSUNGSVERMOGEN
- 13 MAXIMUM WASSERVERBRAUCH
- 02 NOMINALE WARMELEISTUNG
- 18 GRÖÖBE DES KOCHKAMMERS ( B - T - H )
- 20 SCHTZART IP



# MOD:XEVC-0511-EPR



## ENGLISH - DRAWINGS

1	TERMINAL BOARD COVER BOX
2	TERMINAL BOARD POWER SUPPLY
3	UNIPOTENTIAL TERMINAL
6	TECHNICAL DATA PLATE
7	SAFETY THERMOSTAT
8	3/4" THREAD WATER INLET
10	Rotor.KLEAN CONNECTION
11	CAVITY DRAIN PIPE
12	HOT FUMES EXHAUST CHIMNEY
13	ACCESSORIES CONNECTION
27	COOLING AIR OUTLET

## ITALIANO - DISEGNI

1	SCATOLA COPRI MORSETTIERA
2	MORSETTIERA ALIMENTAZIONE
3	MORSETTO EQUIPOTENZIALE
6	TARGHETTA DATI TECNICI
7	TERMOSTATO DI SICUREZZA
8	INGRESSO ACQUA 3/4"
10	INGRESSO Rotor.KLEAN
11	SCARICO CAMERA DI COTTURA
12	USCITA FUMI CALDI
13	COLLEGAMENTO ACCESSORI
27	USCITA ARIA DI RAFFREDDAMENTO

## FRANCAIS - ENCOMBREMEN

1	CHAUMARD
2	BOITE A BORNES D'ALIMENTATION
3	SUPPORT BORNE EQUIPOTENTIELLE
6	PLAQUETTE SEGNALETIQUE
7	THERMOSTAT DE SECURITE
8	ARRIVE D'EAU FIETL 3/4"
10	ENTREE Rotor.KLEAN
11	SORTIE DE L'EAU RACCORD
12	SORTIE DES FUMEEES CHAUDES
13	IONCTION DES ACCESSOIRES
27	SORTIE D'EAU DE REFROIDISSEMENT

## ESPAÑOL - DISEÑOS

1	PASA CABLE
2	CAJA DE CONEXION
3	SEDE BORNE EQUIPOTENCIAL
6	TARJETA DE CARACTERISTICAS TECNICAS
7	TERMOSTATO DE SEGURIDAD
8	ENTRADA DE AGUA 3/4"
10	INGRESO Rotor.KLEAN
11	DESCARGA CAMARA DE COCCION
12	SALIDA HUMOS CALIENTES
13	CONEXION ACCESORIOS
27	SALIDA DEL AIRE DE ENFRIAMIENTO

## DEUTSCH - ZEICHNUNGEN

1	KLEMMLEISTENANSCHLUSS
2	ZULEITUNGSKLEMMLEISTE
3	GLEICHPOTENTIELLE KLAMMER
6	TYPENSCHILD
7	SICHERHEITSTHERMOSTAT
8	WASSEREINZUG 3/4" GEWINDE
10	Rotor.KLEAN EINGANG
11	WASSERAUSLASS GEWINDE
12	ABZUGSHAUBE
13	ZUBEHÖRTEILENVERBINDUNG
27	KÜHLLUFTAUSTRITT

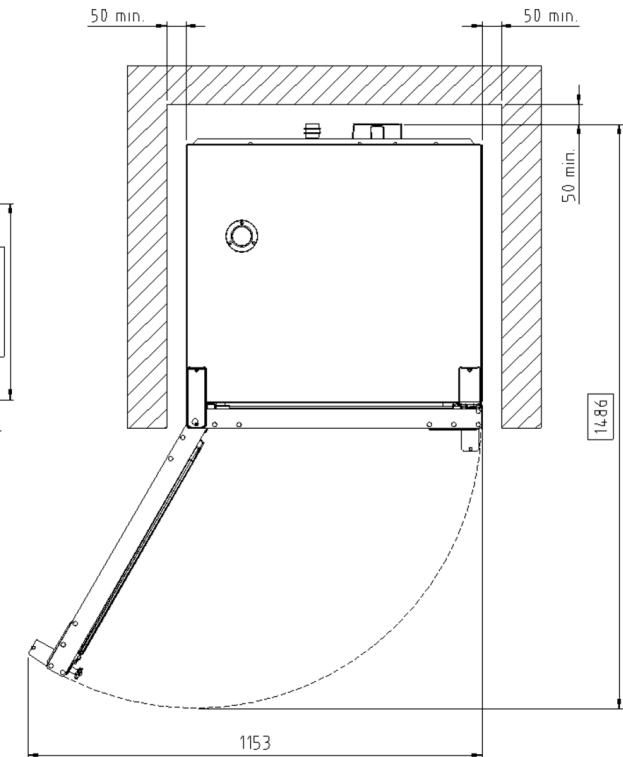
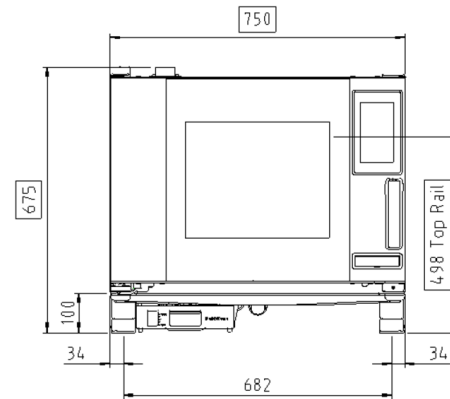
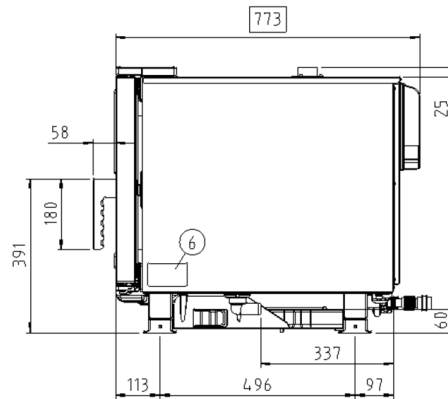
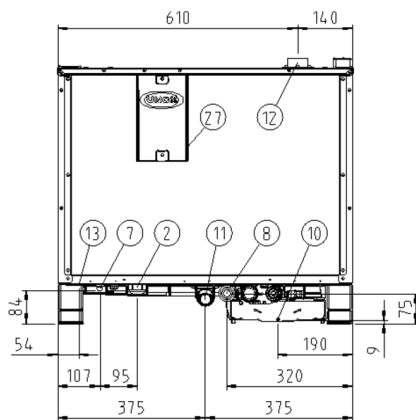

# MOD:XEVC-0511-EPR

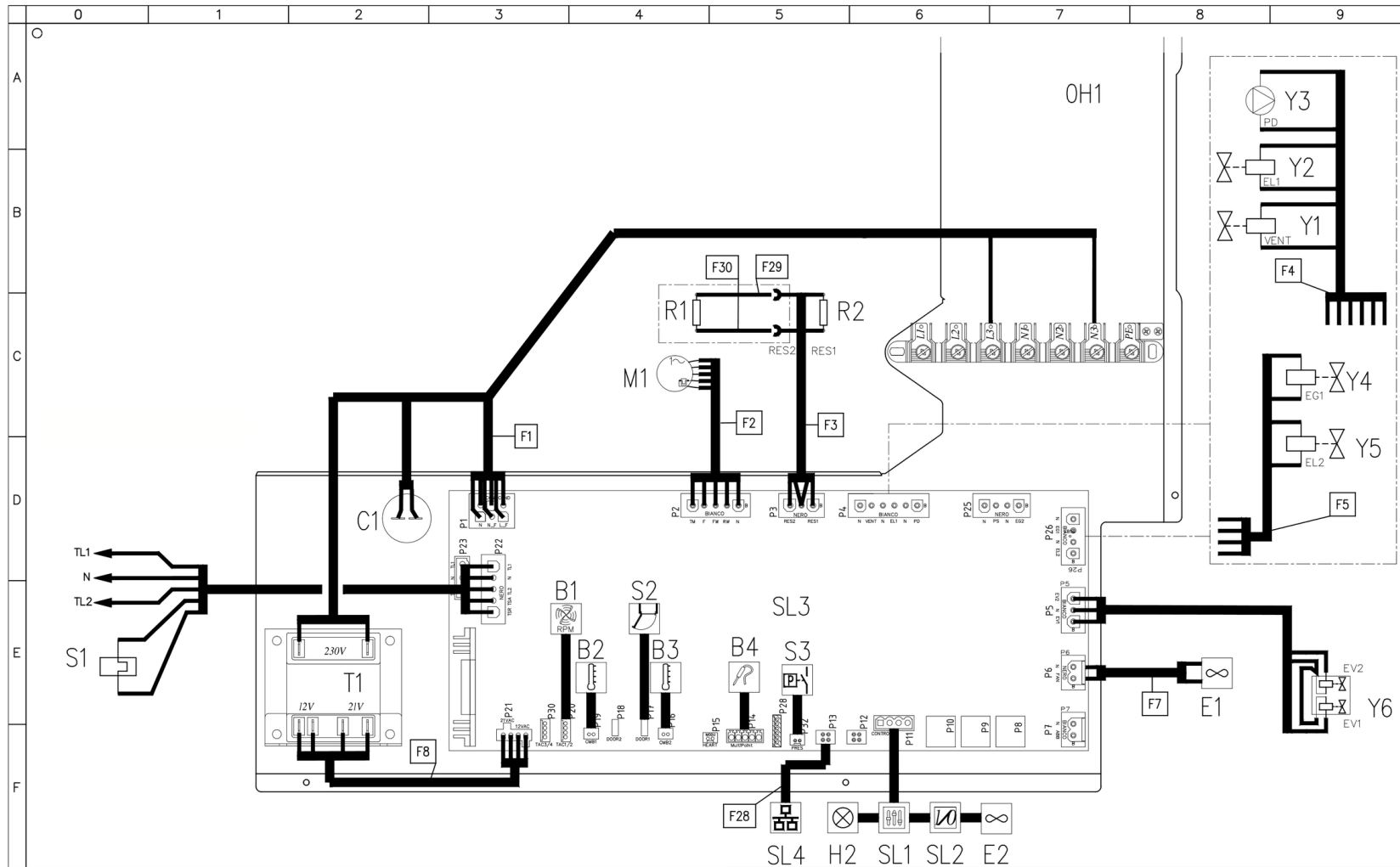

# MOD:XEVC-0511-EPR

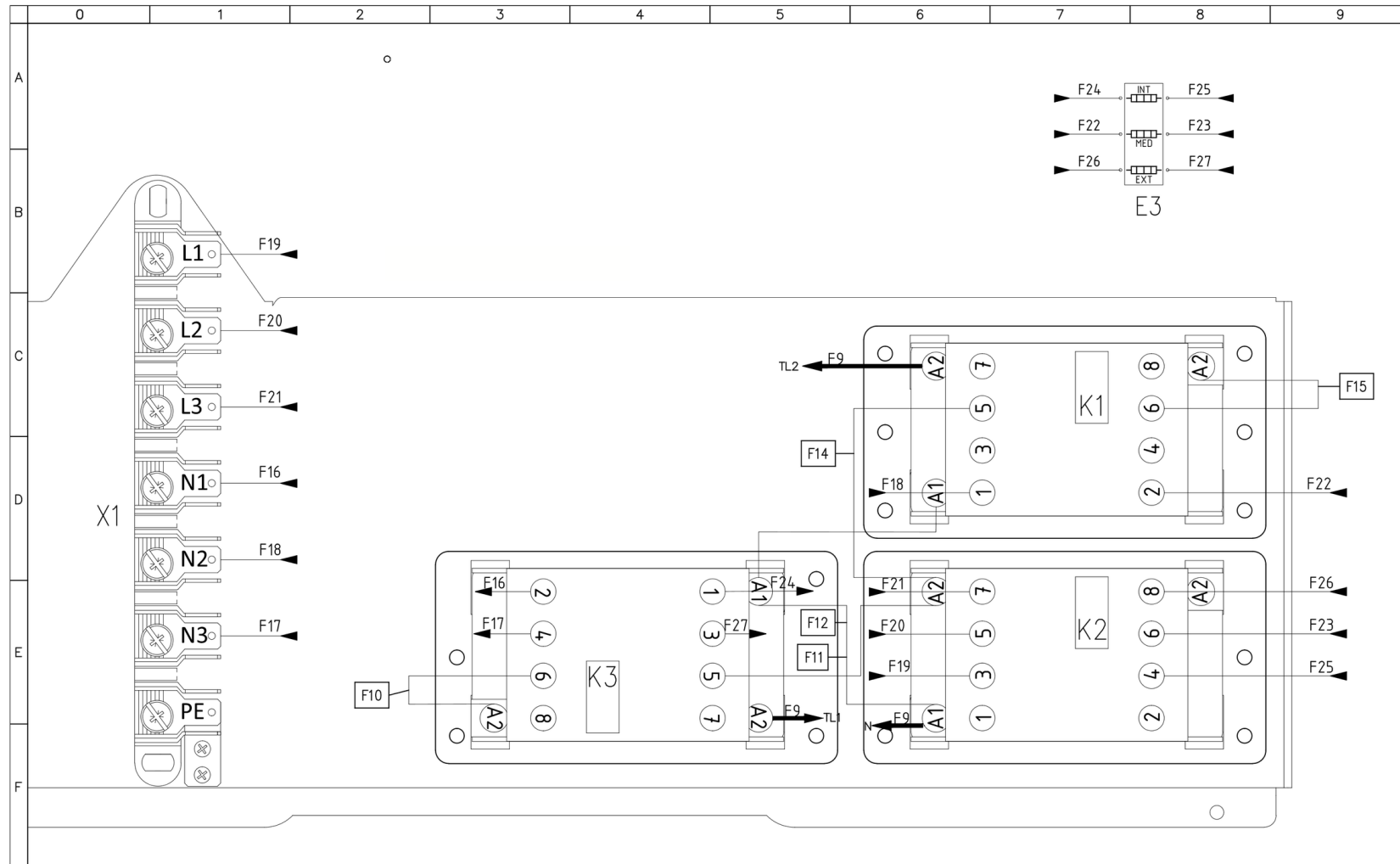

# MOD:XEVC-0511-EPR



	0	1	2	3	4	5	6	7	8	9
A										
B										
C										
	Sigle	ITALIANO	ENGLISH	FRANCAIS	ESPAÑOL	DEUTSCH				
	B1	SENSORE VELOCITA MOTORE	MOTOR SPEED SENSOR	CAPTEUR DE VITESSE MOTEUR	SENSOR DE VELOCIDAD MOTOR	GESCHWINDIGKEITSSENSOR				
	B2,B3	SONDA CAMERA	TEMPERATURE PROBE	SONDE DE CHAMBRE	SONDA CAMARA	GARRAUMTEMPERATURFUHLER				
	B4	SONDA AL CUORE	CORE PROBE	SONDE A COEUR	SONDA CORAZON	KERNTEMPERATURFUHLER				
	C1	CONDENSATORE	MOTOR CAPACITOR	CONDENSATEUR	CONDENSADOR	KONDENSATOR				
	E1,E2	VENTOLA RAFFREDDAMENTO	COOLING FAN	TURBINE DE REFROIDISSEMENT	TURBINA DE REFRIGERACION	LÜFTER				
	E3	ELEMENTO RISCALDANTE	HEATING ELEMENT	ELEMENT DE CHAUFFAGE	RESISTENCIA DE CALEFACCIÓN	HEIZUNG				
	H2	LUCE CAMERA	OVEN LIGHT	ECLAIRAGE DE CHAMBRE	LUZ CAMARA	BELEUCHTUNG				
	K1,K2,K3	TELERUTTORE	CONTACTOR	TELERUPTEUR	TELERRUPTOR	RELAIS				
	M1	MOTORE	MOTOR	MOTEUR	MOTOR	MOTOR				
	R1,R2	RESISTENZA DI MODULAZIONE VENTILATORE	MOTOR MODULATION RESISTANCE	RESISTANCE DE MODULATION VENTILATEUR	RESISTENCIA MODULACION VELOCIDAD	WIDERSTAND LOW FAN				
	S1	TERMOSTATO SICUREZZA	SAFETY THERMOSTAT	THERMOSTAT DE SECURITE	TERMOSTATO DE SEGURIDAD	SICHERHEITS THERMOSTAT				
	S2	MICRO INTERRUTTORE PORTA	DOOR MICROSWTICH	MICROINTERRUPTEUR DE PORTE	MICROINTERRUPTOR PUERTA	TURKONTAKTSCHALTER				
	S3	PRESSOSTATO	PRESSURE SWITCH	PRESSOSTAT	PRESÓSTATO	DRUCKSCHALTER				
	SL1	SCHEDA CONTROLLO	CONTROL BOARD	CARTE DE CONTROLE	TARJETA DE CONTROL	KONTROLL PLATINE				
	SL2	SCHEDA 1/0 – USB	1/0 BOARD – USB	CARTE 1/0 – USB	TARJETA 1/0 – USB	1/0 PLATINE – USB				
	SL3	SCHEDA POTENZA	POWER CARD	CARTE DE PUISSANCE	POWERPLATINE	TARJETA POTENCIA				
	SL4	BRIDGE ETHERNET	BRIDGE ETHERNET	BRIDGE ETHERNET	BRIDGE ETHERNET	BRIDGE ETHERNET				
	T1	TRASFORMATORE	TRANSFORMER	TRANSFORMATEUR	TRANSFORMADOR	TRASFORMATORE				
	X1	MORSETTIERA	CONTACTOR	BORNIER	CONNECTOR	KLEMMLEISTE				
	Y1	DRY MAXY	DRY MAXY	DRY MAXY	DRY MAXY	DRY MAXY				
	Y2,Y4,Y5	ELETTROVALVOLA ACQUA	WATER SOLENOID VALVE	ELECTROVANNE EAU	ELECTROVALVULA	ELEKTROVENTIL				
	Y3	POMPA	PUMP	POMPE	BOMBA	PUMPE				
	Y6	ELETTROVALVOLA ACQUA	WATER SOLENOID VALVE	ELECTROVANNE EAU	ELECTROVALVULA	ELEKTROVENTIL				
D										
E										
F										

ED1408A  
POWER SUPPLY - CONNECTION DIAGRAM

380-415V ~ 3PH + N + PE 50/60Hz

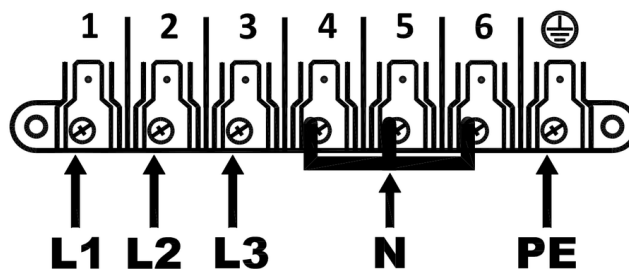

220-240V ~ 3PH + PE 50/60Hz

